



W150PL Food Mixer

Project _____
 Item _____
 Quantity _____
 CSI Section 11400 _____
 Approval _____
 Date _____

W150PL Food Mixer

Models

W150PL



Standard Features

- Powerful 5.5 hp motor
- Variable speeds from 50 to 250 RPM
- Power Bowl Lift.
- Overload protection and no voltage release
- No bowl adaptors required for the down-size bowls
- Locking pin on tools instead of shaft.
- Neoprene feet to minimize walking and rusting
- Permanently lubricated planetary head and attachment hub case
- 15-minute timer with HOLD feature
- Stainless steel 150-qt. bowl, wire whip and dough hook
- Alloy flat beater
- Bowl Truck with Handle
- Stir/ Jog Feature

Options & Accessories

- 80-qt. bowl and accessories
- Bowl scraper in 150-qt. and 80-qt. sizes
- Stainless steel wing whip
- Pastry knife
- Mark IV programmable controls
- Ergo (tall column)
- Bowl Screen Ingredient Chute

Specifications

Mixing system

The VARIMIXER W150PL is a planetary mixer with a variable speed drive system. The mixer frame consists of a column with welded-on feet, and a top traverse closed by a stainless steel cover.

The bowl is mounted in bowl arms which are manually raised and locked simultaneously - or lowered and opened, respectively. The column contains the motor and the bowl arm mechanism. The top traverse contains the transmission system consisting of the moveable pulleys, the intermediate belt drive and the planetary head. Start and stop push buttons are mounted on the frontplate along with a 15-minute electrical timer with a HOLD feature. Mixing tools are mounted in a bayonet shaft in the planetary head.

Construction

Mixer frame of heavy-gauge, welded, rolled steel plate. Durable powder coated finish used on those surfaces not constructed of stainless steel. Top cover, splash apron and planetary head cap in heavy-gauge stainless steel. Molded PVC feet pads. Bowls in stainless steel. Mixing tools in cast aluminum or stainless

steel. Bayonet shaft in stainless steel. Variable speed V-belt transmission based on precision machined cast iron pulleys. Springloaded moveable pulleys in the variable speed drive for automatically adjusting of the tension of the special V-belt. Planetary mixer head of unique design. The planetary head revolves in heavy-duty ball and needle bearings around the main shaft. Precision milled beveled gear on the main shaft engages the bayonet shaft and the fixed internal gear ring through a double set of milled gears obtaining extra high torque capabilities of the mixing tools. Precision milled cast iron bowl arms lower and raise the bowl and clamp it in a precise position relative to the mixing tool allowing for small tolerances between tool extremities and the bowl.



5489 Campus Drive
 Shreveport, LA 71129 USA

Tel: 318-219-7046
 Tel: 1-800-222-1138
 Fax: 318-635-3131
 E-mail: mix@varimixer.com

www.varimixer.com
 Bulletin No. W150PL 03/10



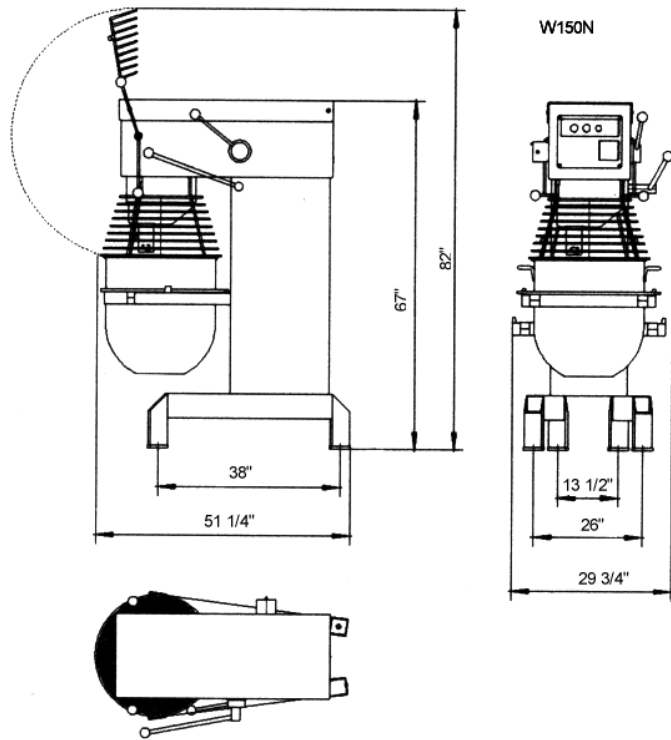

DIMENSIONS

MODEL NO.	CAPACITY	OVERALL SIZE (cm)			NET WEIGHT	SHIPPING INFORMATION					
		HEIGHT	WIDTH	LENGTH		WEIGHT	CLASS	CU. FT.	DIMENSIONS		
W150PL	Large Bowl. 150-Qt. Small Bowl 80-Qt..	67" (170.18 cm)	29 3/4" (75.56 cm)	51 1/4" (130.17 cm)	1147 lbs. (520.27 kg)	1397 lbs. (633.67 kg)	85	84	H 78" (198.12cm)	W 37" (93.98cm)	L 55" (139.7cm)

ELECTRICAL DATA FOR MOTOR**

*208-240VAC Supply/60 HZ/3 Phase
 Wires (including. Ground)4
 Motor Power.....HP.....5.5
 Amperes, full load.....A 16
 No power cord included

CAPACITY CHART

Mashed Potatoes	Whip or Beater	110 lbs.
Whipped Cream	Whip	32 Qts.
Muffins	Beater	195 lbs.
Layer Cake	Beater	175 lbs.
Pie Dough	Pastry Knife	135 lbs.
Pancake Batter	Whip or Beater	50 Qts.
Cookie Dough	Beater or Hook	160 dz.
Donuts, Yeast	Hook	170 lbs.
Donuts, Cake	Beater	225 lbs.
Bread Dough (65% AR)	Hook	175 lbs.
Pizza Dough (50% AR)	Hook	190 lbs.

MIXING SPEED

Agitator Speed.....Min.....50
 Agitator Speed.....Max.....250

%AR= $\frac{\text{weight of water}}{\text{weight of flour}}$

Batch size and/or speed reduction is required if any of the following conditions exist.

1. High Gluten Flour
2. AR % under 40%
3. Water Temperature under 65 Degrees F

*On the nominal motor voltage, + or - 10% tolerance is allowed.

** Also available in 480/60/3, 380/50/3, 220/50/3, 220/50/1, - not submitted for UL listing.

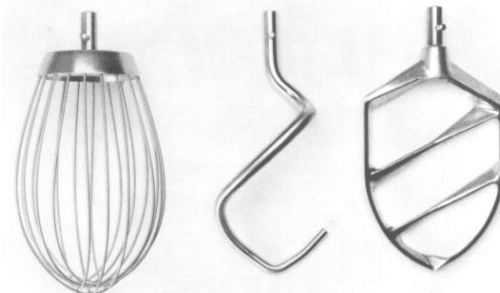

Standard tools: Whip, hook and beater.