

PRODUCT:

QUANTITY:

ITEM#:

Designed Smart.

Increased Performance In Cooking

- Unique Heating system, incorporating special heating elements that transfer heat energy to griddle surface more efficiently than traditional models.
- Fast startup to cooking temperatures (reaches 350 degrees in 11 minutes).
- Provides fast recovery with heat levels reaching 450 degrees.

Safety Features

- New bull-nose front extension protects employees from burns.

Saves Time and Clean-Up Labor Cost

- Maintenance is easier with bottom-mounted grease collection pan.
- Stainless steel is easy to wipe clean.

Built Solid.

Built to Last!

- Thick, stainless steel construction on front panel and top skirt protects against kitchen "wear and tear" and rust.
- 3/4 inch polished steel griddle surface stands up to years of high output cooking.
- Griddle plate is fully welded to base.
- Welded construction in frame base.

Reliability backed by APW Wyott's Warranty

- All APW Wyott cooking equipment is backed by a 3-year limited warranty and a one-year on-site labor warranty.
- Certified by the following agencies:



COUNTERTOP ELECTRIC GRIDDLE

APW Wyott Design Features

- Stainless steel construction.
- 4" adjustable legs.
- 12" cooking sections for zone control.
- 3/4" flat polished steel griddle plate.
- 3-3/16" spatula-width stainless steel front grease trough.
- 4" x 1" grease chute.
- 4 gallon grease collection drawer.
- 3" stainless steel backsplash.
- Sloped stainless steel side splashes.
- Easy-to-read control knobs.



APW Wyott Foodservice Equipment Company

729 Third Avenue • Dallas, TX 75226 • 800-527-2100 • 1-214-421-7366 • Fax 1-214-565-0976

For more information e-mail us at: Info@APWwyott.com

Rev. 1/1/2003

See reverse side for product specifications.

Models: EG-24H EG-36H EG-48H

PRODUCT:

QUANTITY:

ITEM#:

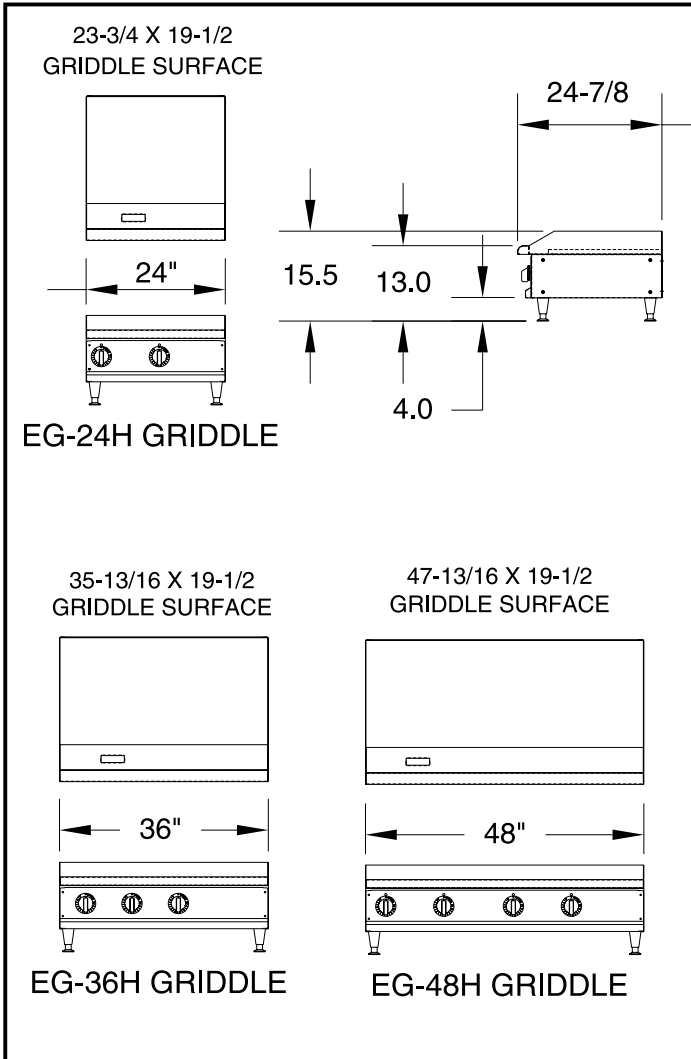

Countertop Electric Griddle

PRODUCT SPECIFICATIONS

Construction:

Heavy-duty stainless steel front and top skirt with aluminized steel sides and back. Welded construction. 4" adjustable legs.

Electrical Specifications:

EG-24H:	208V, 6.75 KW, 32.5 Amps 230V, 8.2 KW, 35.9 Amps 240V, 9 KW, 37.5 Amps
EG-36H:	208V, 10 KW, 48.7 Amps 230V, 12.4 KW, 53.9 Amps 240V, 13.5 KW, 56.3 Amps
EG-48H:	208V, 13.5 KW, 65 Amps 230V, 16.5 KW, 71.9 Amps 240V, 18 KW, 75 Amps

Terminal block located on right side of unit.

Overall Dimensions:

EG-24H:	15-1/2" H x 24" W x 24-7/8" D (39.2 cm x 61 cm x 62.4 cm)
EG-36H:	15-1/2" H x 36" W x 24-7/8" D (39.2 cm x 91.4 cm x 62.4 cm)
EG-48H:	15-1/2" H x 48" W x 24-7/8" D (39.2 cm x 122 cm x 62.4 cm)

Ship Weight:

EG-24H:	180 lbs. (81.8 kg)
EG-36H:	252 lbs. (114.5 kg)
EG-48H:	342 lbs. (155.4 kg)

F.O.B. Cheyenne, WY

World Class Support

World Class Sales Support to assist you with finding the right solution to your operation's needs. Call Customer Service at (800) 527-2100 or Fax your request to (214) 565-0976. For more information about APW Wyott's World Class Support and High Performance Equipment, look us up on the Internet at www.APWwyott.com

Most Extensive Service System in the Industry! APW Wyott has three levels of service support for your needs:

- Direct Service Hot Line to Service Department, call (800) 752-0863.
- To find the Registered Service Technician in your area, call Automated Service Hot Line at (800) 733-2203.